

Frame and Drum Assembly

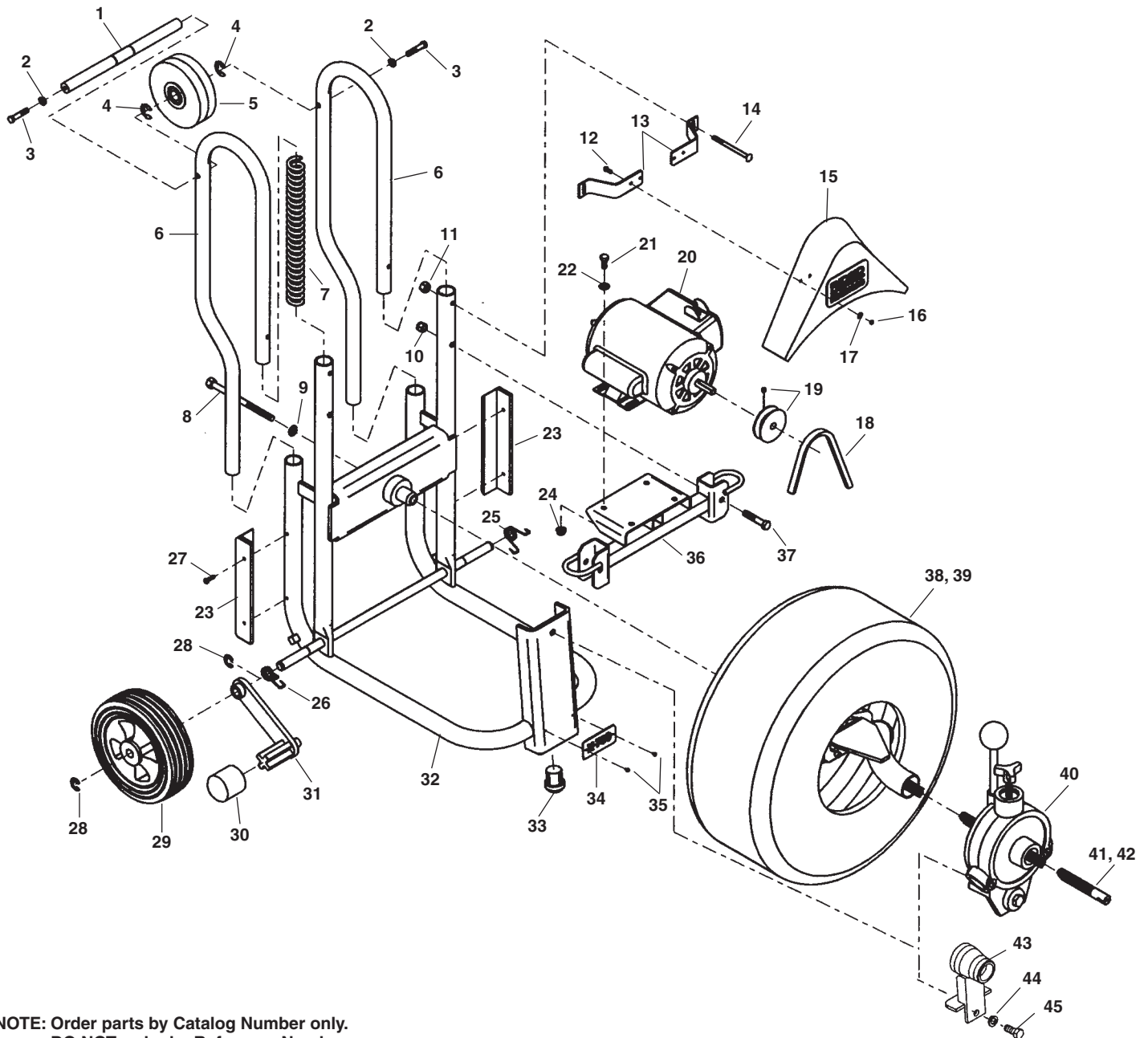

**NOTE: Order parts by Catalog Number only.
DO NOT order by Reference Number.**

Ref. No.	Catalog No.	Description	Ref. No.	Catalog No.	Description	Ref. No.	Catalog No.	Description
1	46632	Axle	16	87970	Nut 10-24 (4)	30	23607	End Cap (2)
2	60080	Lock Washer $\frac{5}{16}$ "	17	61310	External Lock Washer (4)	31	43912	Stabilizer (2)
3	43847	Hex Bolt $\frac{5}{16}$ " - 18 x $1\frac{1}{2}$ "	18	43997	Drive Belt	32	43902	Frame Assembly
4	60050	Retaining Ring	19	43982	Motor Pulley	33	61470	Rest Button
5	46637	Loading Wheel	20	43977	120V 60Hz Motor Assembly	34	43907	Name Plate
6	43952	Handle (2)		45052	220/240V 50Hz Motor Assembly	35	76730	Drive Screw (4)
7	43957	Compression Spring		44517	220/240V 50Hz Motor (Europe)	36	43987	Motor Mount Assembly
8	43937	Screw $\frac{1}{2}$ " - 13 x 5" Hex Head (Torque to 60-65 ft. lbs.)		44522	220/240V 50Hz Motor (Australia)	37	43992	Hex Head Screw $\frac{3}{8}$ "-16 x 2"
9	43942	$\frac{1}{2}$ " Lock Washer (2)	21	61130	Screw (4)	38	43637	Drum Assembly w/ $\frac{5}{16}$ " Pigtail
10	43947	Lock Nut	22	60060	$\frac{3}{16}$ " Flat Washer (4)	39	41982	Drum Assembly w/ $\frac{3}{4}$ " Pigtail
11	45407	$\frac{1}{4}$ " - 20 Handle Nut (2)	23	43927	Stair Climber (2)	40	43642	AUTOFEED® Assembly
12	43962	Screw 10 - 24 x $\frac{1}{2}$ " (4)	24	27517	$\frac{5}{16}$ "-18 Lock Nut	41	44117	$\frac{3}{4}$ " Pigtail Assembly
13	43967	Guard Bracket (2)	25	43922	Stabilizer Spring R.H.	42	44122	$\frac{5}{8}$ " Pigtail Assembly
	44502	Guard Bracket (Eur. & Aust.) (2)	26	43917	Stabilizer Spring L.H.	43	54427	Manual Feed Assembly
14	43972	Carriage Bolt (2)	27	43932	Self Tapping Screw (4)	44	43942	$\frac{1}{2}$ " Lock Washer
15	44027	Belt Guard	28	42580	Retaining Clip (4)	45	45287	Hex Head Screw $\frac{1}{2}$ " - 13 x 2"
			29	93325	Wheel (2)			

Drum Assembly

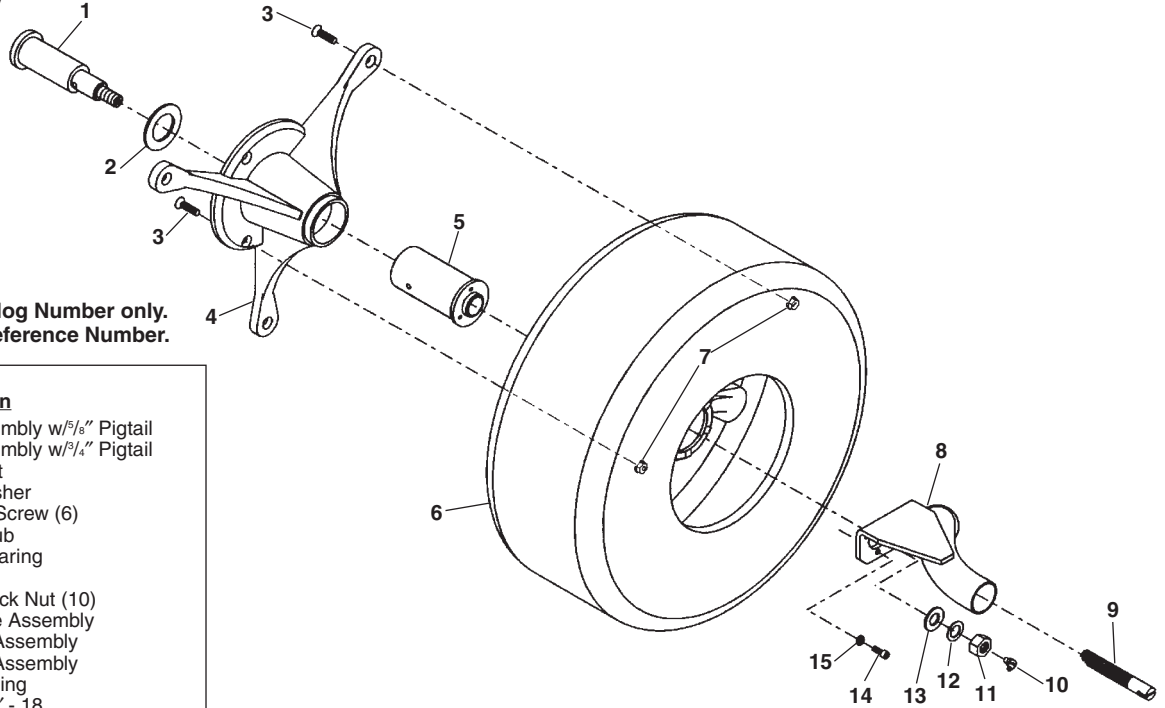

NOTE: Order parts by Catalog Number only. DO NOT order by Reference Number.

Ref. No.	Catalog No.	Description
—	43637	Drum Assembly w/5/8" Pigtail
—	41982	Drum Assembly w/3/4" Pigtail
1	44002	Drum Shaft
2	44007	Thrust Washer
3	44012	Flat Head Screw (6)
4	44017	Support Hub
5	44022	Spindle Bearing
6	44032	Drum
7	27517	5/16" - 18 Lock Nut (10)
8	44037	Guide Tube Assembly
9	44117	3/4" Pigtail Assembly
	44122	5/8" Pigtail Assembly
10	89815	Grease Fitting
11	44057	Hex Nut 5/8" - 18
12	44047	Internal Lock Washer
13	44042	5/8" Flat Washer
14	44052	Screw 1/4" - 20 x 5/8" S.H. (3)
15	45150	1/4" Lock Washer (3)

AUTOFEED® Assembly

Ref. No.	Catalog No.	Description
—	43642	AUTOFEED® Assembly
1	93580	Feed Knob
2	93500	Retaining Ring
3	93600	Knurled Nut
4	93475	Ball Holder
5	93375	Spring
6	44062	Moveable Roller Holder
7	44067	AUTOFEED® Housing
8	43942	1/2" Lock Washer (2)
9	45287	Screw 1/2" - 13 x 2" Hex Head (Torque to 25-30 ft. lbs.)
10	44092	Roller Holder Cam (2)
11	45417	Stationary Roller Hld (2)
12	44082	Actuator Pin (6)
13	44077	Ball Bearing (3)
14	93460	Spacer (6)
15	44102	Bolt Retainer
16	44112	Retaining Ring
17	44107	Feed Actuator
18	93630	Clutch Handle Assembly
19	44097	Torsion Spring (3)
20	68367	Thrust Washer (4)
21	68372	Spacer (2)

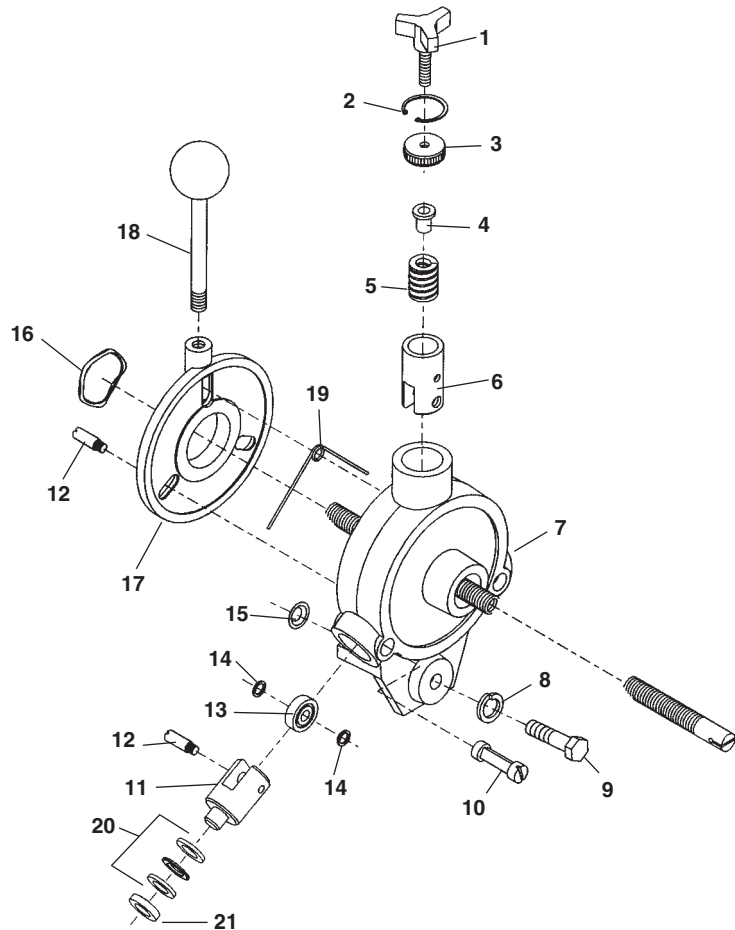

120V 60 Hz Motor

**NOTE: Order parts by Catalog Number only.
DO NOT order by Reference Number.**

Ref. No.	Catalog No.	Description
1	23507	Rubber Boot
2	61490	Switch Guard
3	23512	Rubber Washer
4	41817	Switch
5	23687	FOR/REV Label
6	44877	Lead Wire Assembly
7	32992	Air Switch
8	96265	Strain Relief
9	67422	Thermal Protector
10	70447	120V 60Hz Motor Assembly (Includes Ref. No. 1 - 9)
11	50507	120V Power Cord w/GFCI
12	44635	Wire Nut
13	44072	Foot Switch Assembly
14	35142	Hose Clamp

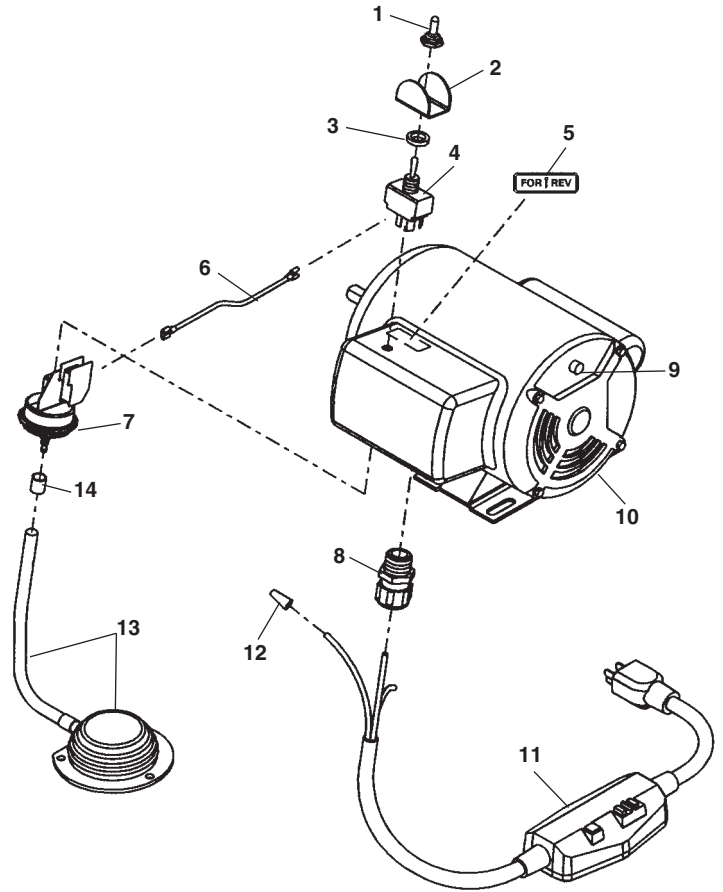

Wiring Diagram 120V 60 Hz Motor

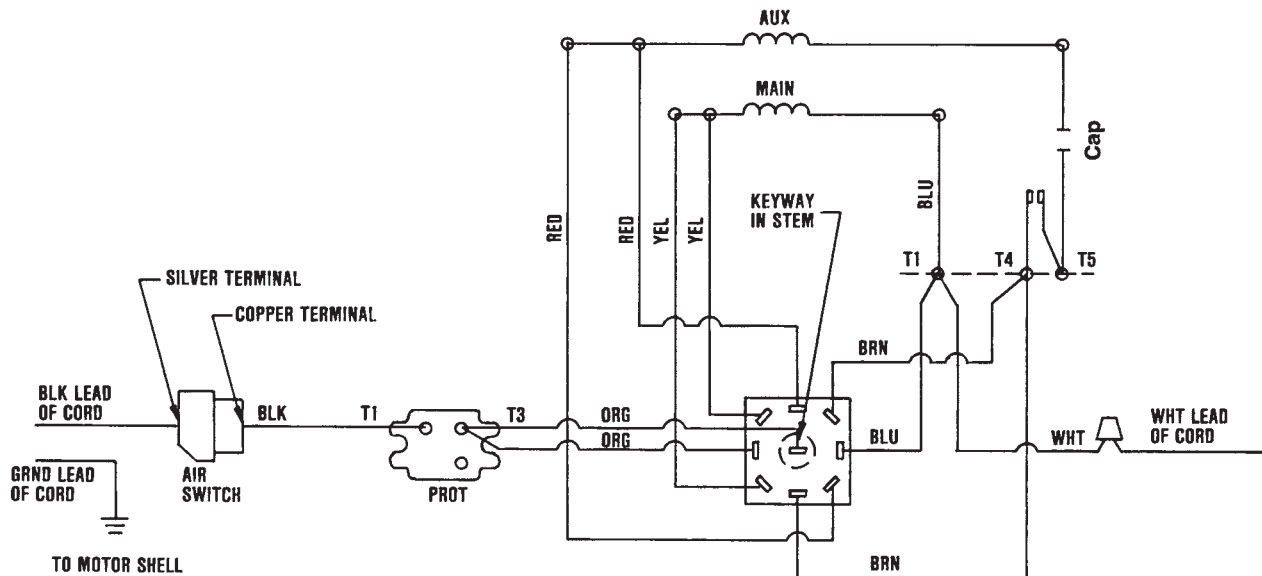

50Hz Motor

**NOTE: Order parts by Catalog Number only.
DO NOT order by Reference Number.**

Ref. No.	Catalog No.	Description
1	44882	Jumper Wire Assembly
2	44862	Switch (Australia & Europe)
3	44877	Lead Wire Assembly
4	32992	Air Switch
5	35142	Hose Clamp
6	44072	Foot Switch Assembly
7	44635	Wire Nut
8	27187	Strain Relief
9	45052	220/240V 50Hz Motor Assembly
	44517	220/240V 50Hz Motor Assy. (Eur.)
	44522	220/230V 50Hz Motor Assy. (Aust.)
10	15707	220V Power Cord
	39562	220V Power Cord (Europe)
	44512	240V Power Cord (Australia)
11	67417	Thermal Protector

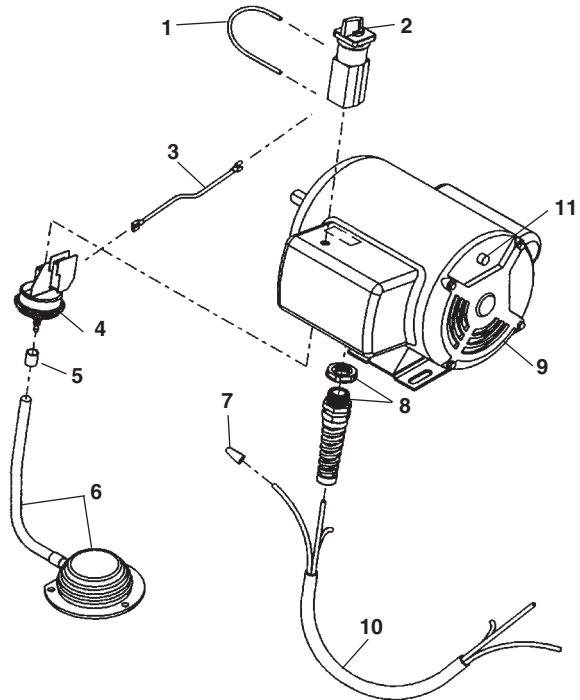

220/240V 50Hz Wiring Diagram

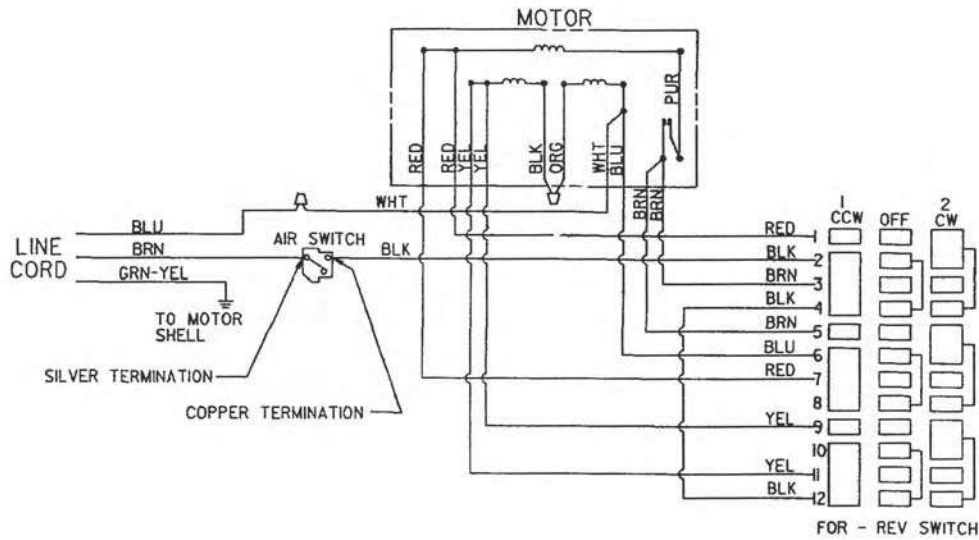

110V 50Hz Wiring Diagram

